

- Unpack the *LONWORKS Option Kit* and verify that all components are present and undamaged.

Part	Qty.
<i>LONWORKS Option Board</i> (UUX000258)	1
LONWORKS Data Diskette	1
Installation Guide (IG.AFD.20)	1

- Verify that that the drive is one of the following series: E7, P7, F7, or G7. The *LonWorks Option* is only compatible with these drive series.
- Apply power to the drive or E7L panel and verify that they function correctly. This includes running the drive through the drive keypad (or the Bypass keypad, in case of E7L). Refer to the appropriate technical manual for information on connections and operation.
- Remove power and wait for the drive charge lamp to be completely extinguished. Measure and verify the drive's DC BUS voltage to be at a safe level.
- Remove the operator keypad and drive cover(s).
 - Remove the operator keypad by depressing the tab on the right side of the keypad and then pulling it out. In E7L, the keypad may already have been removed and mounted on the enclosure door.
 - Remove the drive's front cover until the entire control card is exposed. The number of covers and the removal procedure varies by drive series and capacity. Consult the drive's technical manual for details. In E7L, these covers may already have been removed and the keypad mounted on the door.
 - Remove the option card hold-down plug on the left side of the drive case by carefully compressing the top and bottom until it becomes free of its holder and then pulling it out.

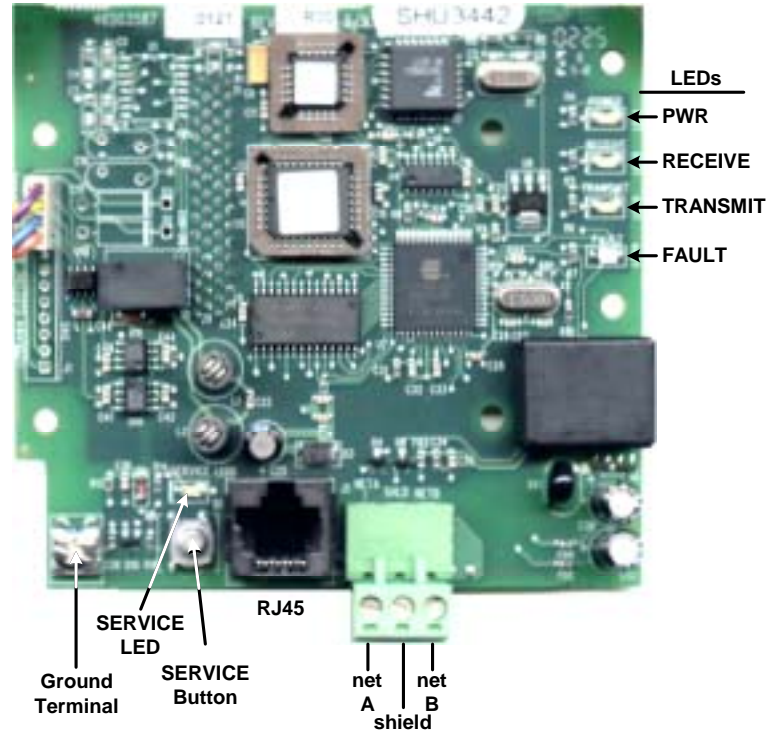

- Mount the *LONWORKS Option* on the drive.
 - Align the 2CN connector on the back of the *LONWORKS Option* with its mating 2CN connector on the front of the drive's control board. Align the two standoffs on the front of the drive's control board with the two holes on the right side of the *LONWORKS Option Board*.
 - Press the *LONWORKS Option* firmly onto the drive's 2CN connector and standoffs until the 2CN connector is fully seated and the drive standoffs have locked into their appropriate holes.
 - **Standard Connection** - Route the four wires from the *LONWORKS Option* along the left side of the control board and connect them directly to the R+, R-, S+ and S- terminals on the I/O terminal assembly as shown below.
 - **E7L Connection** - Route the four wires from the *LONWORKS Option* to terminal board TB4 on the E7L control card. The E7L control board is typically mounted on the left inside wall of the E7L enclosure. Connect the wires as shown below.
 - Connect a ground wire from the ground terminal on the option board to the ground terminal on the drive's terminal assembly on the drive. The PE-Ground should be used for the E7L control board.
 - **Standard Termination** - Set the Termination Switch S1-1 to ON as shown below. This is independent of whether the drive is the first or last device on the *LonWorks* network.
 - **E7L Termination** - Set the Termination Switch S1 to ON. This is independent of whether the drive is the first or last device on the *LonWorks* network.

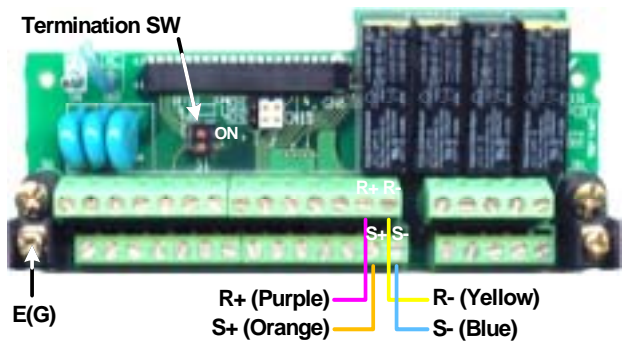

Standard Connection

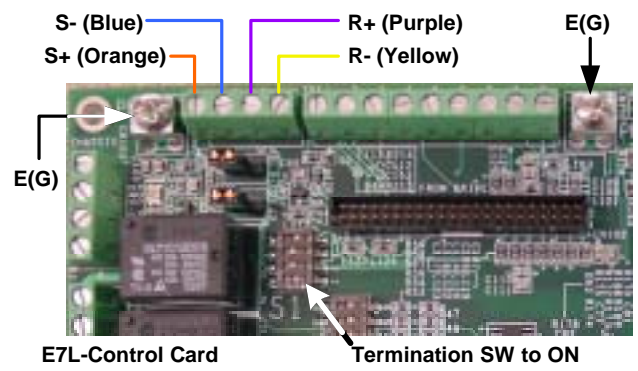

E7L Connection

 Setting the drive parameters

- Remove power from the drive and wait for the charge lamp to be completely extinguished. Wait at least five additional minutes for the drive to be completely discharged. Measure the DC BUS voltage and verify that it is at a safe level.
- Reinstall the operator keypad and all drive covers. Apply power to the drive.
- Set parameter A1-01 to 2, Advanced.
- Set parameters b1-01 and b1-02 to their appropriate values. Refer to the table below for available b1-01 and b1-02 values. Reference Selection and Operation Method Selection can have different values depending on the application. To control both frequency and run/stop over the network, set both b1-01 and b1-02 to 2, Serial Communications.
- Set parameter H5-01 to 1F (31)
- Set parameter H5-02 to 3, 9600 baud
- Set parameter H5-03 to 0, No Parity
- Set parameter H5-06 to 5, 5ms transmission wait
- Set parameter H5-07 to 0, Disabled
- Set parameter H5-08 to 0, MODBUS
- Parameters H5-04 (Stopping Method at Communications Fault), H5-05 (Serial Fault Detection) and H5-09 (CE Detect Time) should be set according to the desired drive performance during a communications timeout or failure.
- After all drive parameters have been set, power cycle the drive. Communications parameters will not take affect until power has been removed from the drive until the charge lamp has been extinguished and restored.
- **For E7L or E7B Bypass-Panel applications, refer to the parameter table and electrical schematic accompanying the unit for parameter and DIP-switch settings.**

Parameter	Function	Data	+/- Limits - Description	Default
A1-01	Access Level	0	Operator	2
		1	User	
		2	Advanced	
B1-01	Reference Selection	0	Digital Operator	1
		1	Terminals	
		2	Serial Communication (LONWORKS)	
		3	Option PCB	
		4	Pulse Input	
B1-02	Operation Method Selection	0	Digital Operator	1
		1	Terminals	
		2	Serial Communication (LONWORKS)	
		3	Option PCB	
H5-01	Serial Communications Address	1F	0 – 1F	1F
H5-02	Serial Baud Rate Select	0	1200 baud	3
		1	2400 baud	
		2	4800 baud	
		3	9600 baud (LONWORKS)	
		4	19200 baud	
H5-03	Serial Parity Select	0	None (LONWORKS)	0
		1	Even parity	
		2	Odd parity	
H5-06	Transmit Wait	5	5 – 65ms	5
H5-07	RTS Control Select	0	Disabled (LONWORKS)	0
		1	Enabled	
H5-08	Protocol Select	0	MODBUS (LONWORKS)	0
		1	N2 (Metasys)	
		2	P1 (APOGEE)	

- ☐ Connect to the LONWORKS network.
 - Connect the network to the *LONWORKS Option* as shown.

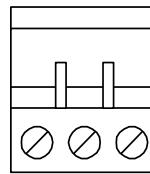

N S N
e H e
t L t
A D B

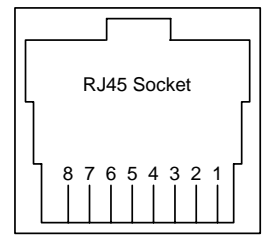

N N
E E
T T
A B

☐ Network Identification and Node Configuration

The *LONWORKS Option* is shipped **unconfigured**. This implies that the application is loaded and communications parameters are defined but the option has not been installed on the network. On power up, an unconfigured node can be recognized by the **SERVICE LED** blinking at 2Hz.

Network identification is accomplished with an installation tool. Unique network identities are established by pairing “logical” addresses with a device’s 48-bit Neuron ID.

■ SERVICE Button

Each option card has a Service Button. If using a configuration tool utilizing this feature, press the Service Button when prompted to do so. When pressed, a broadcast message is sent which contains the Neuron ID and program ID. This uniquely identifies the node on the network. This method works best for small networks or with portable installation tools.

■ Find and Wink

When it is impractical to press each node’s Service Button for installation (e.g. in large networks or a node is physically enclosed), the “find and wink” installation method is useful. With this method, the installation tool queries the network for all unconfigured nodes. Nodes respond with their Neuron ID and a logical address is assigned. A “wink” command can then be sent to each logical address. In response to this command, the **TRANSMIT** and **RECEIVE** LED’s will blink rapidly for several seconds. In this manner, the exact physical location of each node can be identified.

■ Reclaiming a Node

- A node can be “reclaimed”, or returned to its unconfigured state, as follows:
 - Remove power from the drive and wait for the charge lamp to be completely extinguished.
 - Press and hold the Service Button.
 - Re-apply drive power, continuing to press and hold the Service Button.
 - After approximately 5 seconds, the SERVICE LED should begin flashing at a 0.5 Hz rate, indicating the unconfigured state. This procedure sets both domain table entries to “undefined” and sets the channel ID to 0.

☐ LED Status Indicators and Diagnostics

LED Display					Condition	Solution
PWR	Receive	Transmit	Fault	Service		
				BLINK 0.5Hz	Option is Not Configured	<ul style="list-style-type: none"> • Configure Option
				FLASH 1s ON _2s OFF _Cont ON	Application missing	<ul style="list-style-type: none"> • Download application image file • Assign network Identity
OFF	OFF	OFF	OFF	OFF	Power not supplied	<ul style="list-style-type: none"> • Check that drive has power • Check option card seating in CN2 connector
ON	BLINK	BLINK	BLINK	OFF	Communications not established	<ul style="list-style-type: none"> • Check drive parameters (refer to table above) • Check connection between option and drive
ON			ON	OFF	Communications Loss	<ul style="list-style-type: none"> • Check network cable connections
ON	FLASH		OFF	OFF	Normal communications	Flash each time serial task is complete Approximately 0.5Hz when drive is at STOP Approximately 1.0Hz when drive RUN is active
ON		FLASH	OFF	OFF	Normal communications	Flash for every 5 network variables updates

Copies of this Installation Guide along with all technical manuals in PDF format and support files may be obtained from either the CD supplied with the drive or from www.drives.com. Printed copies of any Yaskawa manual may be obtained by contacting the nearest Yaskawa office. Information on LONWORKS may be obtained at www.echelon.com

Reference documents:

E7 Technical Manual – TM.E7.02

P7 Technical Manual – TM.P7.02

F7 Technical Manual – TM.F7.02

G7 Technical Manual – TM.G7.01

E7 Parameter Access Technical Manual – TM.E7.11

P7 Parameter Access Technical Manual – TM.P7.11

F7 Parameter Access Technical Manual – TM.F7.11

GPD is a trademark of Yaskawa, Inc.

MODBUS[®] is a registered trademark of Schneider Automation, Inc.

LONWORKS[®] is a registered trademark of Echelon Corporation.

YASKAWA ELECTRIC AMERICA, INC.

Drives Division
16555 W. Ryerson Rd., New Berlin, WI 53151, U.S.A.
Phone: (800) YASKAWA (800-927-5292) Fax: (262) 782-3418
Internet: <http://www.drives.com>

YASKAWA ELECTRIC AMERICA, INC.

Chicago-Corporate Headquarters
2121 Norman Drive South, Waukegan, IL 60085, U.S.A.
Phone: (800) YASKAWA (800-927-5292) Fax: (847) 887-7310
Internet: <http://www.yaskawa.com>

MOTOMAN INC.

805 Liberty Lane, West Carrollton, OH 45449, U.S.A.
Phone: (937) 847-6200 Fax: (937) 847-6277
Internet: <http://www.motoman.com>

YASKAWA ELECTRIC CORPORATION

New Pier Takeshiba South Tower, 1-16-1, Kaigan, Minatoku, Tokyo, 105-0022, Japan
Phone: 81-3-5402-4511 Fax: 81-3-5402-4580
Internet: <http://www.yaskawa.co.jp>

YASKAWA ELETRICO DO BRASIL COMERCIO LTDA.

Avenida Fagundes Filho, 620 Bairro Saude Sao Paulo-SP, Brasil CEP: 04304-000
Phone: 55-11-5071-2552 Fax: 55-11-5581-8795
Internet: <http://www.yaskawa.com.br>

YASKAWA ELECTRIC EUROPE GmbH

Am Kronberger Hang 2, 65824 Schwalbach, Germany
Phone: 49-6196-569-300 Fax: 49-6196-888-301

MOTOMAN ROBOTICS AB

Box 504 S38525, Torsas, Sweden
Phone: 46-486-48800 Fax: 46-486-41410

MOTOMAN ROBOTEC GmbH

Kammerfeldstrabe 1, 85391 Allershausen, Germany
Phone: 49-8166-900 Fax: 49-8166-9039

YASKAWA ELECTRIC UK LTD.

1 Hunt Hill Orchardton Woods Cumbernauld, G68 9LF, Scotland, United Kingdom
Phone: 44-12-3673-5000 Fax: 44-12-3645-8182

YASKAWA ELECTRIC KOREA CORPORATION

Paik Nam Bldg. 901 188-3, 1-Ga Euljiro, Joong-Gu, Seoul, Korea
Phone: 82-2-776-7844 Fax: 82-2-753-2639

YASKAWA ELECTRIC (SINGAPORE) PTE. LTD.

Head Office: 151 Lorong Chuan, #04-01, New Tech Park Singapore 556741, Singapore
Phone: 65-282-3003 Fax: 65-289-3003

TAIPEI OFFICE (AND YATEC ENGINEERING CORPORATION)

10F 146 Sung Chiang Road, Taipei, Taiwan
Phone: 886-2-2563-0010 Fax: 886-2-2567-4677

YASKAWA JASON (HK) COMPANY LIMITED

Rm. 2909-10, Hong Kong Plaza, 186-191 Connaught Road West, Hong Kong
Phone: 852-2803-2385 Fax: 852-2547-5773

BEIJING OFFICE

Room No. 301 Office Building of Beijing International Club,
21 Jianguomanwai Avenue, Beijing 100020, China
Phone: 86-10-6532-1850 Fax: 86-10-6532-1851

SHANGHAI OFFICE

27 Hui He Road Shanghai 200437 China
Phone: 86-21-6553-6600 Fax: 86-21-6531-4242

SHANGHAI YASKAWA-TONJI M & E CO., LTD.

27 Hui He Road Shanghai 200437 China
Phone: 86-21-6533-2828 Fax: 86-21-6553-6677

BEIJING YASKAWA BEIKE AUTOMATION ENGINEERING CO., LTD.

30 Xue Yuan Road, Haidian, Beijing 100083 China
Phone: 86-10-6232-9943 Fax: 86-10-6234-5002

SHOUGANG MOTOMAN ROBOT CO., LTD.

7, Yongchang-North Street, Beijing Economic & Technological Development Area,
Beijing 100076 China
Phone: 86-10-6788-0551 Fax: 86-10-6788-2878

YEA, TAICHUNG OFFICE IN TAIWAN

B1, 6F, No.51, Section 2, Kung-Yi Road, Taichung City, Taiwan, R.O.C.
Phone: 886-4-2320-2227 Fax: 886-4-2320-2239

Data subject to change without notice